



## MS7220 ArgusSCAN™

### Features

- **Fully automatic scanning operation**
- **Modular mounting with four stand configurations**
- **RS232 auxiliary port for adding peripherals**
- **User-replaceable cables**
- **Easy to set up and configure**
- **Custom data editing using Bits 'n' Pieces®**
- **Programmable depth of field**
- **Compatible with OPOS systems**



The MS7220 ArgusSCAN™ is an aggressive omnidirectional laser bar code scanner ideal for retail, convenience, liquor, grocery and specialty stores. Because it is engineered with a large, high-speed scan area and a bright 650 nm laser, ArgusSCAN boasts exceptionally high first pass read accuracy for maximum productivity.

Offering four stand configurations, the ArgusSCAN is adaptable to a variety of applications. The modular design allows it to be mounted either horizontally or vertically, and a flexible post can be added, raising the scanner an additional 76 mm (3") off the counter top. Combine this with the MS7220's programmable depth of field, and the ArgusSCAN can be customized to meet the requirements of even

the most unique scanning environment.

Multiple interfaces and data parsing make the ArgusSCAN compatible with most cash registers right out of the box, and the RS232 auxiliary port allows for check readers, magstripe readers or bar code scanner input. Simply plug a Metrologic hand-held scanner into the auxiliary port for scanning bulky or heavy items.

The MS7220 ArgusSCAN is MetroSet® 2, MetroSelect® and MetroPOS® compatible, making configuration easy. And the MS7220's compatibility with Metrologic's PowerLink user replaceable cables allows users to quickly replace damaged cables.

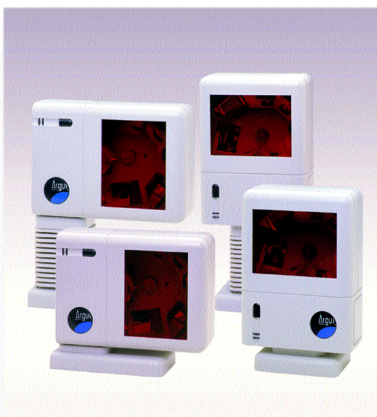

# MS7220 ArgusSCAN™

## OPERATIONAL

Light Source	Visible Laser Diode 650 nm ± 10 nm
Laser Power	0.678 mW (peak)
Depth of Scan Field	0 mm - 215 mm (0" - 8.5") for 0.33 mm (13 mil) bar codes
Width of Scan Field	38 mm (1.5") @ 40 mm (1.6") ; 135 mm (5.3") @ 215 mm (8.5")
Scan Speed	2000 scan lines per second
Scan Pattern	5 fields of 4 parallel lines (omnidirectional)
Number of Scan Lines	20
Minimum Bar Width	0.13 mm (5.2 mil)
Decode Capability	Autodiscriminates all standard bar codes; for other symbologies call Metrologic
System Interfaces	PC Keyboard Wedge, RS232, OCIA, Light Pen, IBM 46xx, Stand Alone PC Keyboard, USB
Print Contrast	35% minimum reflectance difference
Number Characters Read	Up to 80 data characters
Roll, Pitch, Yaw	360°, 60°, 60°
Beeper Operation	7 tones or no beep
Indicators (LED)	Green = laser on, ready to scan; Red = good read, decoding

## MECHANICAL

Dimensions	123 mm H x 65 mm D x 168 mm W (4.8" H x 2.6" D x 6.6" W)
Footprint On Stand	127 mm x 67 mm (5" x 2.68") or 93 mm x 67 mm (3.5" x 2.68")
Weight	0.91 Kg (2 lbs)
Termination	Four 10-pin modular RJ45
Cable	Standard 2.1 m (7') straight; optional 2.7 m (9') coiled; for other cables call Metrologic
Mount (optional)	Fully adjustable

## ELECTRICAL

Input Voltage	5.0 VDC ± 0.25 V
Power	1.9 W
Operating Current	360 mA
DC Transformers	Class II; 5.2 VDC @ 650 mA
Laser Class	CDRH: Class IIa; EN60825-1:1994/A11:1996 Class 1
EMC	FCC, ICES-003 & EN55022 Class A

## ENVIRONMENTAL

Operating Temperature	0°C to 40°C (32°F to 104°F)
Storage Temperature	-40°C to 60°C (-40°F to 140°F)
Humidity	5% to 95% relative humidity, non-condensing
Light Levels	Up to 4842 Lux (450 footcandles)
Contaminants	Sealed to resist airborne particulate contaminants
Ventilation	None required

## Scan Area

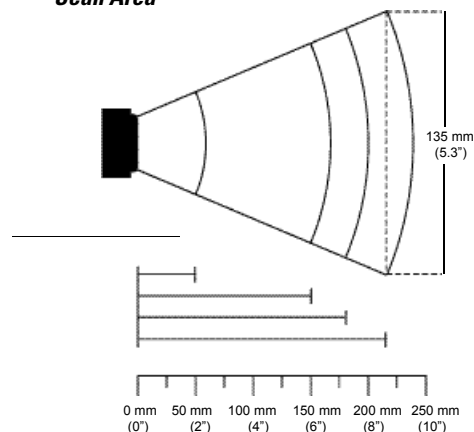

## Dimensions

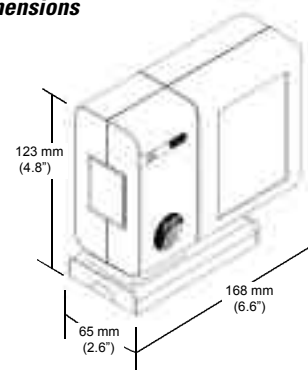

## Port Identification

